

VVR2 Variable Voltage Regulator

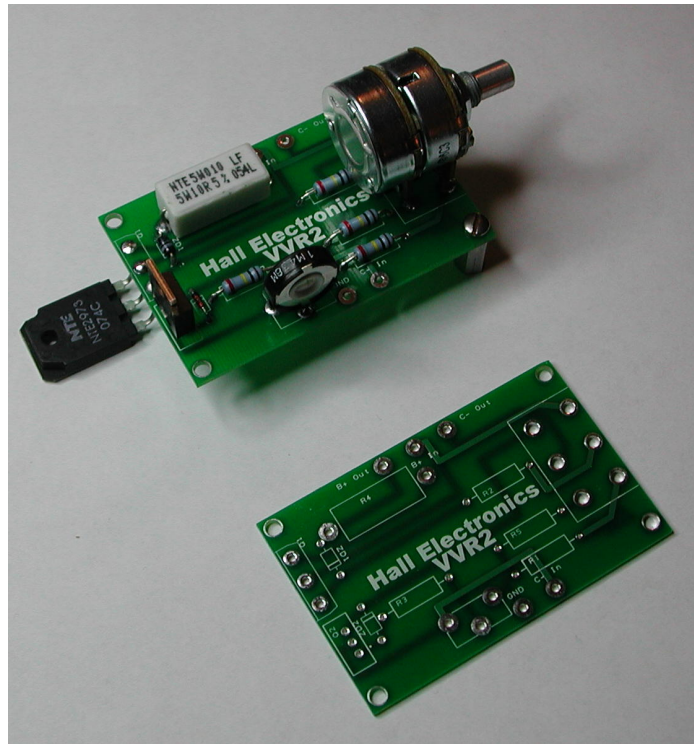

Methods to control the power output in a musical instrument amplifier have been around for a long time. The first patent that I have found for regulating power was filed in October of 1979. Patent number 4,286,492 was granted on 9/1/1981. It was invented by Guy P. Claret and he called it his “Control for Electronic Amplifiers”

“A circuit which allows for simultaneous control of the bias voltages applied to the screen grids and control grids of output tubes while maintaining the ratio of said voltages there by providing a method for selectively varying a single plate characteristic (Power Output) of a tetrode / pentode vacuum tube”

Over the next couple of decades other people came out with different ways to vary the voltages in a guitar amp to change the power level of the amplifier. Both Kevin O’Connor and Dave Zimmerman came up with other ways to modify the power supplies in guitar amplifiers to make the power output from an amp variable.

The VVR is a simple circuit that when installed in a musical instrument amplifier will make the B+ voltage and Bias voltage variable from 100% power to a minimum power level which is selectable by changing resistor values.

While it is a simple circuit it is not a simple mod to install. It should only be installed by a qualified amplifier technician. Use this circuit at your own risk! I do not warranty it, either expressed or implied, for any use in any amplifier. By installing this board in your amplifier, you are agreeing that you will assume all responsibility for its safe operation. If you don't agree with these terms then send the board back in re-sellable condition for a full refund.

You can regulate voltages to just your power tubes or the whole amp or any other portion in between. You need to talk this over with your tech as there may need to be additional parts that need to be installed in addition to the VVR board. It would be impossible for me to offer design assistance to install this in any amplifier that has ever been made. In the following pages, I will try and give you as much info as I have available. The board can be used for either fixed bias or cathode biased amps. Some parts are omitted from the board if you are installing it in a cathode biased amp. See BOMs below

BOM for fixed bias is

- 1) dual 1 meg pot 1/2 watt Linear
- 1) 1meg trim pot 1/2 watt
- 4) 100k 1/2 watt resistors (R1, R2, R3, R5)
- 1) 10 ohm 5w resistor (R4)
- 1) 6v zener 1w (ZD1)
- 1) 12v zener 1w (ZD2)
- 1) NTE 2973 (or equalivent) Mosfet (Q1)
- 1) NTE2372 (or equalivent) Mosfet (Q2)

BOM for the cathode bias is

- 1) single 1 meg pot 1/2 watt linear
- 2) 100k 1/2 watt resistors (R1, R2)
- 1) 10 ohm 5w resistor (R4)
- 1) 6v zener 1w (ZD1)
- 1) NTE 2973 (or equalivent) Mosfet (Q1)



The two pics above show the board populated with parts for both the fixed bias version and the cathode biased version. You can buy the blank boards and assemble the VVR with parts you obtain yourself or you can purchase a preassembled board. I do not sell a kit with board and parts for you to assemble yourself. All of the preassembled boards are tested prior to being shipped. The pot and Mosfet are not installed on the board so that you can installed the board, pot and mosfet in different locations within the amp. If you decide to install it as one unit you will have to mount and solder the pot and mosfet onto the board.

The preassembled kit includes the populated board, a dual pot or single pot (depending on the version you ordered), the Power Mosfet and an insulator to insulate the mosfet from the chassis or heat sink.

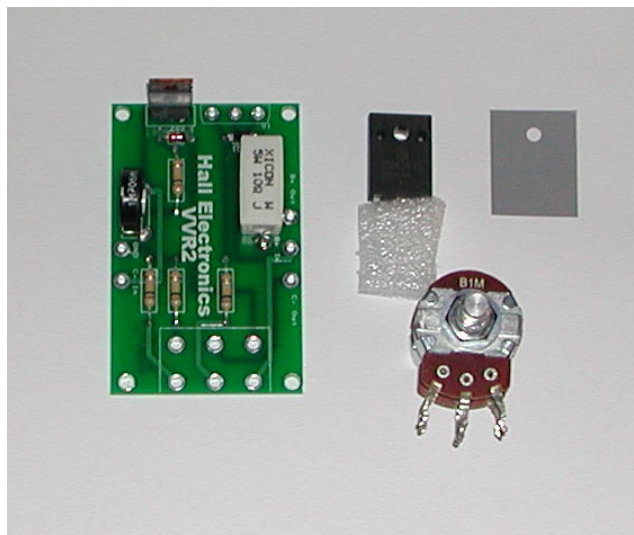

Blank Board Instructions

Follow the pics to install the parts on your board for a **Cathode Biased Amp**

Step1) Install 2 100k ½ watt resistors on the board at locations R1,R2

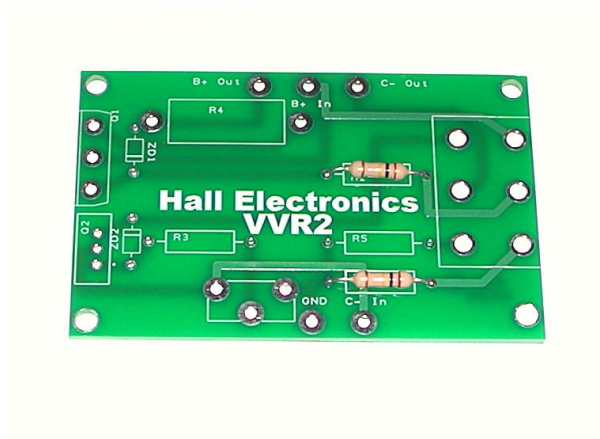

Step2) Install the 6v Zener diode at location ZD1 making sure the banded side of the diode is orientated like the image on the board

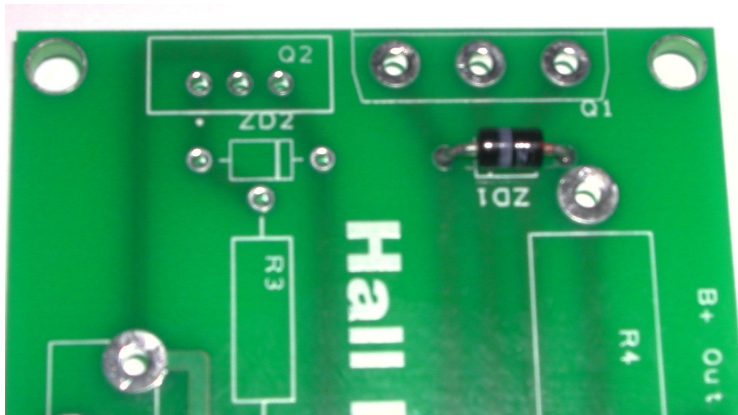

Step 3) Install the 10 ohm 5 watt resistor in the R4 location on the board.

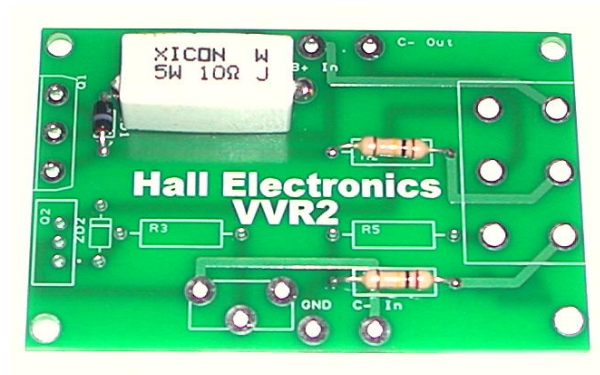

If you are installing the pot and Mosfet external to the board then you are done and can move on to installing the board in the amp. If you are installing the pot and mosfet on the board then go on to step 4

Step 4) Mount the pot on the board in the holes closest to the edge of the board

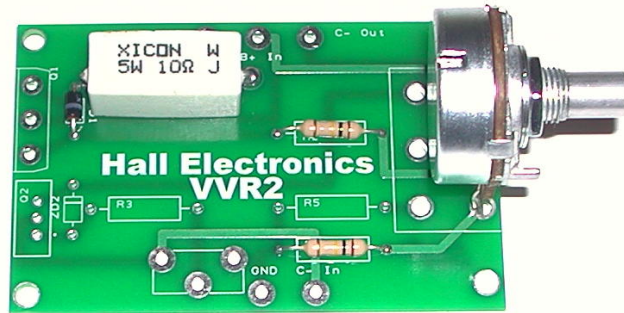

Step5) Mount the mosfet on the board. The mosfet is a static sensitive device. That means that static electricity that builds up in your body can blow the mosfet. Always make sure you use normal static precautions when handling the mosfet. It can be mounted either on top of the board or on the bottom of the board.



Top Mount

Bottom Mount

No matter how you mount the mosfet, you will need to bolt it to the chassis or adequate heat sink to provide proper cooling. ALWAYS make sure you install the insulator provided between the chassis/heatsink and the mosfet or you will damage the mosfet.



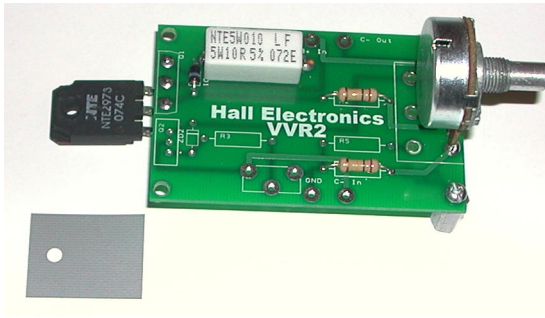

That completes the board assembly for a Cathode Biased Amp.

Additional components need to be installed for a Fixed Bias Amp to control the bias voltage. Follow the steps on this page to mount the parts for a FIXED BIAS AMP. You will be installing a trim pot, a dual ganged pot (in place of the single pot on the Cathode Bias version), 2- 100k ½ watt resistors and an additional zener diode and mosfet.

Step 6) Mount 2 more 100k resistors in locations R3 and R5

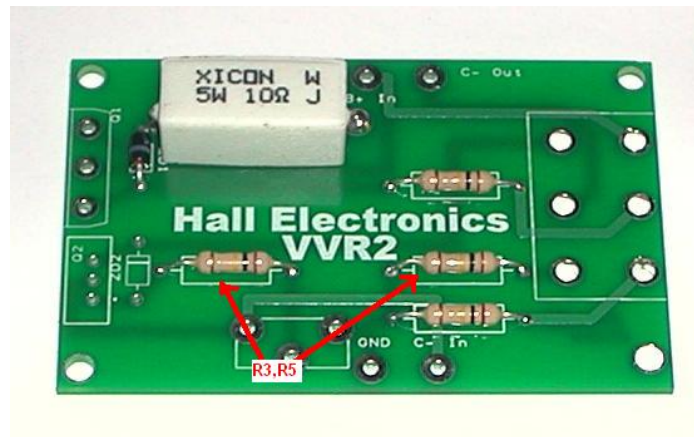

Step 7) Install the 12v Zener (ZD2) at the ZD2 location on the board making sure you have the band on the diode orientated like the image on the board.



Step 8) Install the 1m trim pot on to the board.



Step 9) Install the FET Q2. The FET is installed with the tab side towards the edge of the board. The mosfet is a static sensitive device. That means that static electricity that builds up in your body can blow the mosfet. Always make sure you use normal static precautions when handling the mosfet.

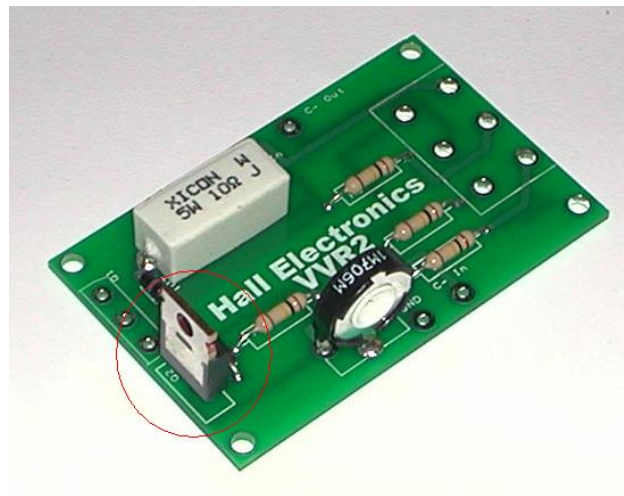

Step 10) The last component to add to the board is the Dual Ganged pot. If you are mounting this external to the board then you can move on to installing the board .



Completed Fixed Bias Board

Installation Instructions

Cathode Bias vs Fixed Bias.

There are two different Bias circuits used in amps. The cathode bias method uses a resistor in series with the cathode of the power tube(s). As current flows through the tube it develops a voltage across the cathode resistor making the cathode positive in respect to the grid of the tube. Looking at it a different way, it also makes the grid negative in respect to the cathode providing a negative bias on the grid. The bias sets the operating point of the tube on a linear portion of its published curve charts provided by the manufacturer in their data sheets. Cathode bias is sometimes called self bias. In a cathode biased amp, as you turn down the B+ voltage using a VVR it causes the tube to draw less current. This in turn causes the voltage drop across the cathode resistor to change, changing the bias point of the tube automatically.

With fixed bias, you have a “Bias supply” that is just like a HV supply in your amp only it creates a negative DC voltage that is applied to the grids of the power tubes. This bias voltage is usually adjustable so that you can dial in the best bias voltage for the tubes you are using. Unlike the Cathode bias the fixed bias doesn't change when you change the B+ voltage in your amp. This makes it a little more complicated to install a variable voltage regulator because you now have to turn down the bias voltage in proportion to the amount you turn down the B+ voltage. The VVR2 has additional circuitry on the board to do just that.

We will talk about installing the board in a cathode bias amp first. The installation is the same in both types of amps as far as regulating the whole amp or just the power section. There are additional components that may need to be installed to make each one work.

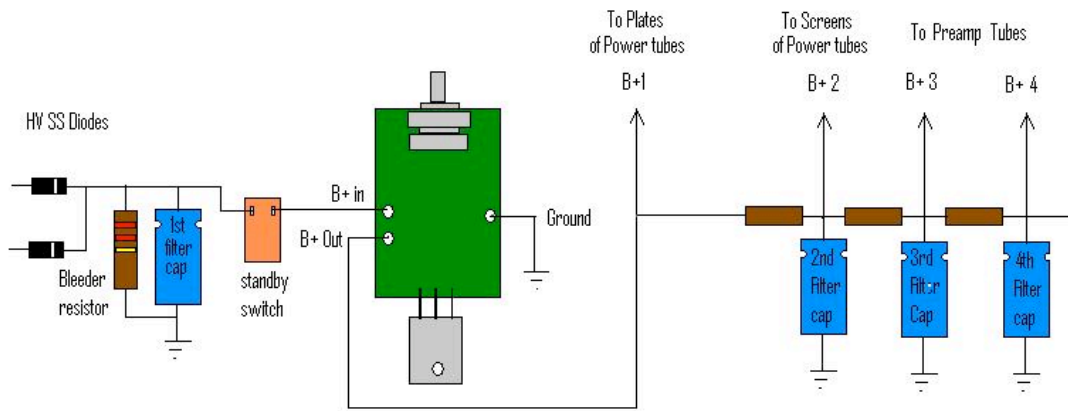

Pictorial Diagram of VVR2 Installed regulating the whole amp

This type installation will turn down all of the voltages in the amp as you adjust the power control on the board. This kind of implementation will require you to move the 1meg resistor on your guitar input jack and the installation of a cap between the input and the grid of the first tube. You also need to install another 1meg resistor and cap between the vol control and the grid of the tube it feeds. See the schematics below.

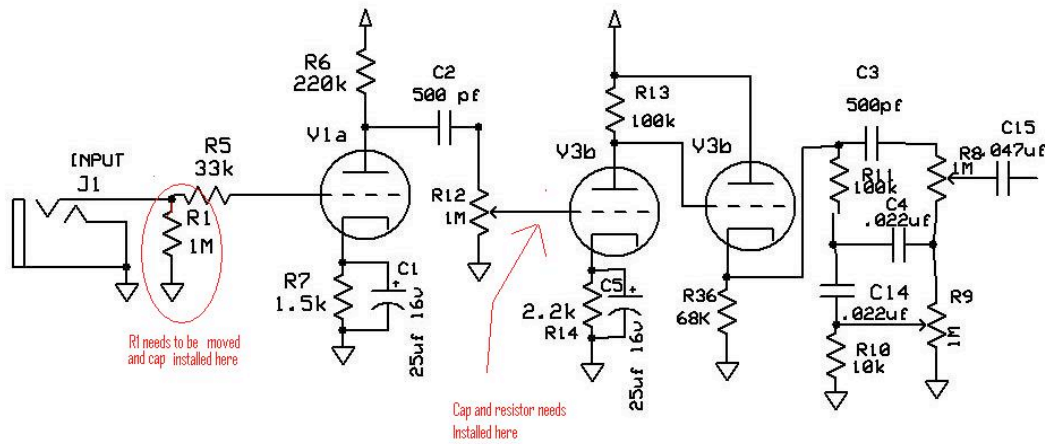

Normal Preamp before installing VVR

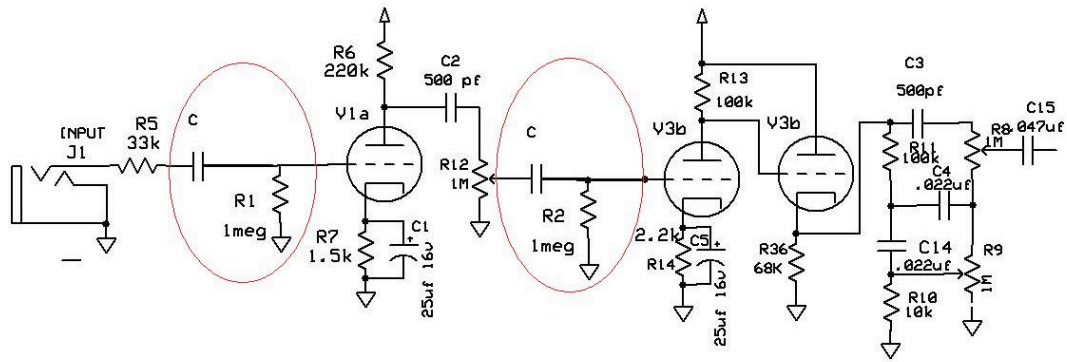

Preamp after moving R1 and adding the 2 capacitors and R2 (circled)

While you can play with the value of the caps a good rule of thumb is to start out with the same size caps that are feeding the signal from your phase inverter to the grids of the power tubes. This should not cause any change in tone compared to the original tone of the amp. Some people just use .1uf. The reason for the changes are because at low voltages the signal on the grids of the two preamp tubes leaks a little dc voltage onto the guitar pot and vol control when the signal hitting these grids drive them more positive than the bias voltage applied. In simple terms it removes the scratchiness from the guitar and amp vol controls.

You can also limit how low the voltage can go so that the grid of the preamp tubes can't leak DC onto the pots. This can be accomplished by changing the value of R1 (and R2 for fixed bias boards). The board comes with a 100k installed for R1 and R2. By changing them to a higher value you will limit how low the voltage will go on the regulator. Basically, they are in series with the 1meg pot. Since the 100k is about 10% of the value of the 1meg pot you limit the voltage to only go down to 10% of the highest voltage. For example, if you had a B+ of 400v and a 100k resistor for R1 you could vary the voltage from 400 v down to 40v (40V being 10% of 400) If you went with a 200k resistor for R1 you could limit the range from 400 to 80v. By limiting how low the voltage goes you can find a point where you won't need to add the caps and 1meg resistor or move the 1meg on the input jack. The only drawback to this method is that you are also limiting the range of how quiet the volume of the amp will go

Regulating the Power Tubes Only

This method is preferred by some, just like regulating the whole amp is preferred by others. This method will split the power supply into 2 different parts. One part is regulated, which supplies voltage to the power tube plates and screens, and the other part is left normal to run the preamp tubes. This method will also require you to make an

additional mod to the amp. You will need to add a Master Volume so that the signal coming from the preamp tubes running at normal voltages won't overdrive the power tubes running at reduce voltages. The general consensus is to add a Post Phase Inverter Master volume or PPIMV. This works well in a Push Pull amp but there is no Phase inverter in a Single Ended amp and a normal Master Volume control will work fine between the last preamp stage and the power tube(s). You will also need to install 2 1N4007 diodes to isolate the two different sections of the power supply so they don't interact with each other.

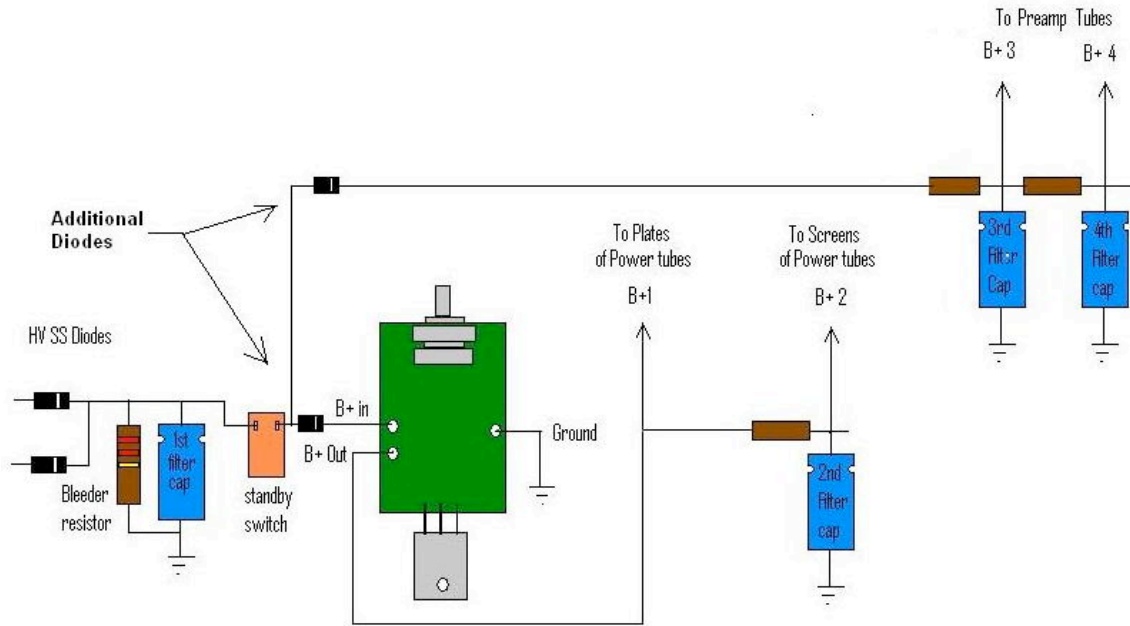

Pictorial Diagram of VVR2 Installed Regulating the Power Tubes Only

Installing the Fixed Bias Board

The installation of the fixed bias board is identical to the Cathode Biased Board with additional connections for the bias tracking. On the board you find a couple of holes marked C- IN and C- out. This is for the bias voltage. Hooking positive voltage to these pads can damage the bias mosfet. Different bias schemes have been used in many different amps. I have tried to make hooking up the bias part of the board as easy cutting a wire in two and putting the VVR between each end. Your installation may be different.

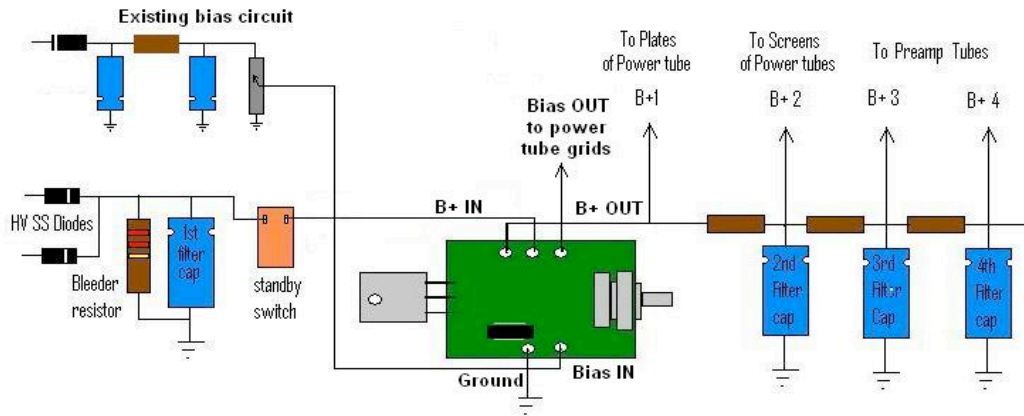

Pictorial Diagram of VVR2 Installed Regulating Bias

Adjusting the Bias

There is usually a bias pot in amps that have a fixed bias power supply. The example of one that doesn't would be some Mesa Boogie amplifiers. In an amp that has no bias control find the wire going to the grid resistors of the power tubes. Measure the voltage and if it is negative then disconnect this wire and hook it to the C- IN (Negative Bias IN) on the board. Run another wire from C- OUT on the board back to where you removed the original wire. You will now be able to adjust the bias using the bias control on the board or you can turn the trim pot on the board until your negative voltage reaches its highest (Actually lowest) negative number on a volt meter. This would then give you the original factory setting before you installed the VVR.

If you have an existing bias pot in your amp you have two options. You can max out the original bias control in the amp and use the trimmer on the VVR board to adjust your bias or you can max out the trimmer on the board and use the original bias control to adjust your bias. Please note that if you use the bias pot on the board it will be adjustable from your highest negative bias reading all the way to zero. It is a 1meg pot and a course adjustment. If you decide to use the existing bias pot in the amp you will get what ever rang it had to begin with. This is the way to go if you have external jacks and a ten turn pot installed so you don't have to remove the amp chassis from the cab.

The procedure to adjust the bias is the same as you would normally use with the exception that you need to make sure the Power Control (Ganged Pot) is set to max B+ voltage. **Setting the bias with the Power control at less than max B+ will cause an over bias condition when the Power control is maxed out.**

FAQ

NTE2973
MOSFET
N-Channel, Enhancement Mode
High Speed Switch

Applications:

- SMPS
- DC-DC Converter
- Battery Charger
- Power Supply of Printer
- Copier
- HDD, FDD, TV, VCR
- Personal Computer

Absolute Maximum Ratings: ($T_C = +25^\circ\text{C}$ unless otherwise specified)

Drain-Source Voltage ($V_{GS} = 0\text{V}$), V_{DSS}	900V
Gate-Source Voltage ($V_{DS} = 0\text{V}$), V_{GS}	$\pm 30\text{V}$
Drain Current, I_D	
Continuous	14A
Pulsed	42A
Maximum Power Dissipation, P_D	275W
Channel Temperature Range, T_{ch}	-55° to $+150^\circ\text{C}$
Storage Temperature Range, T_{stg}	-55° to $+150^\circ\text{C}$
Thermal Resistance, Channel-to-Case, $R_{th(ch-c)}$	0.45°C/W

Electrical Characteristics: ($T_{ch} = +25^\circ\text{C}$ unless otherwise specified)

Parameter	Symbol	Test Conditions	Min	Typ	Max	Unit
Drain-Source Breakdown Voltage	$V_{(BR)DSS}$	$V_{DS} = 0\text{V}$, $I_D = 1\text{mA}$	900	-	-	V
Gate-Source Breakdown Voltage	$V_{(BR)GSS}$	$V_{DS} = 0\text{V}$, $I_G = \pm 100\mu\text{A}$	± 30	-	-	V
Gate-Source Leakage	I_{GSS}	$V_{GS} = \pm 25\text{V}$, $V_{DS} = 0\text{V}$	-	-	± 10	μA
Zero Gate Voltage Drain Current	I_{DSS}	$V_{DS} = 900\text{V}$, $V_{GS} = 0$	-	-	1.0	mA
Gate Threshold Voltage	$V_{GS(th)}$	$V_{DS} = 10\text{V}$, $I_D = 1\text{mA}$	2.0	3.0	4.0	V
Static Drain-Source ON Resistance	$R_{DS(on)}$	$V_{GS} = 10\text{V}$, $I_D = 7\text{A}$	-	0.63	0.85	Ω
Drain-Source On-State Voltage	$V_{DS(on)}$	$V_{GS} = 10\text{V}$, $I_D = 7\text{A}$	-	4.41	5.95	V
Forward Transfer Admittance	$ y_{fs} $	$V_{GS} = 10\text{V}$, $I_D = 7\text{A}$	9	15	-	S

Electrical Characteristics (Cont'd): ($T_{ch} = +25^{\circ}\text{C}$ unless otherwise specified)

Parameter	Symbol	Test Conditions	Min	Typ	Max	Unit
Input Capacitance	C_{iss}	$V_{GS} = 0\text{V}, V_{DS} = 25\text{V}, f = 1\text{MHz}$	-	2900	-	pF
Output Capacitance	C_{oss}		-	290	-	pF
Reverse Transfer Capacitance	C_{rss}		-	50	-	pF
Turn-On Delay Time	$t_{d(on)}$	$V_{DD} = 200\text{V}, I_D = 7\text{A}, V_{GS} = 10\text{V}, R_{GEN} = R_{GS} = 50\Omega$	-	45	-	ns
Rise Time	t_r		-	65	-	ns
Turn-Off Delay Time	$t_{d(off)}$		-	325	-	ns
Fall Time	t_f		-	100	-	ns
Diode Forward Voltage	V_{SD}	$I_S = 7\text{A}, V_{GS} = 0\text{V}$	-	1.0	1.5	V

